

VL863

LTE Vehicle GNSS Terminal

User Manual V1.3

No part of this document may be reproduced, retranslated, or copied in any form or by any means or for profit (electronic, photocopying, taping, etc.) without written permission of the Company. The product specifications and information in this document are for reference only and no prior notice will be given if any change is made. Unless otherwise stated, the content of this document is not a guarantee in any form.

Product Overview

The VL863 is a versatile GPS tracker designed to efficiently manage fleets of passenger vehicles, trucks, and refrigerated transport. With 4G connectivity and 2G fallback, it ensures stable global communication and enables fast, accurate vehicle positioning. The VL863 features built-in CAN functionality (support J1939 and OBD-II) and 1-Wire communication, and is equipped with multiple TTL (RS232-compatible) and RS485 ports, as well as digital inputs and outputs. These features support demanding applications such as vehicle data acquisition, driver identification and behavior monitoring, fuel level detection, cargo temperature monitoring, and two-way voice communication. The device also provides real-time alerts for harsh acceleration, hard braking, and sharp turns to ensure safer and more efficient fleet management. With a built-in Bluetooth module, it supports various Bluetooth sensors. As an added benefit, the GNSS and Bluetooth antennas can be customized for external mounting, providing greater deployment flexibility.

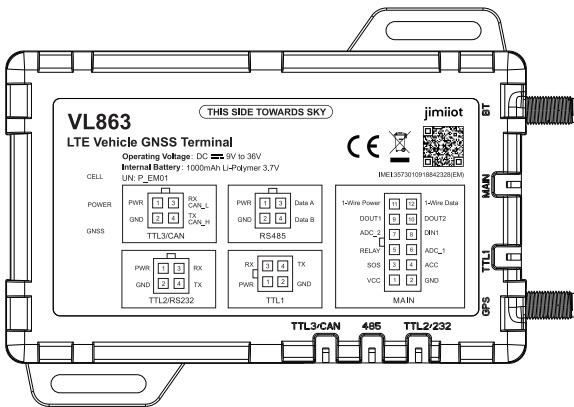

Position tracking

- GPS & LBS positioning
- Real-time location query

Anti-Theft & Security

- Ignition detection
- Power/Fuel cut-off
- SOS emergency call
- Power supply disconnection alert
- Geo-fence alert
- Towing alert
- Vibration alert

Expandable Peripherals & Sensors

- Vehicle door status detection
- Remote door lock/unlock control
- Turn light/buzzer triggering
- Fuel level monitoring
- Temperature monitoring
- Driver identification

Packing List

VL863	1	Unit	/
Power cable	1	Pcs	Cable length (1.5m)
SOS button	1	Pcs	
Relay	1	Pcs	

Interface Specifications

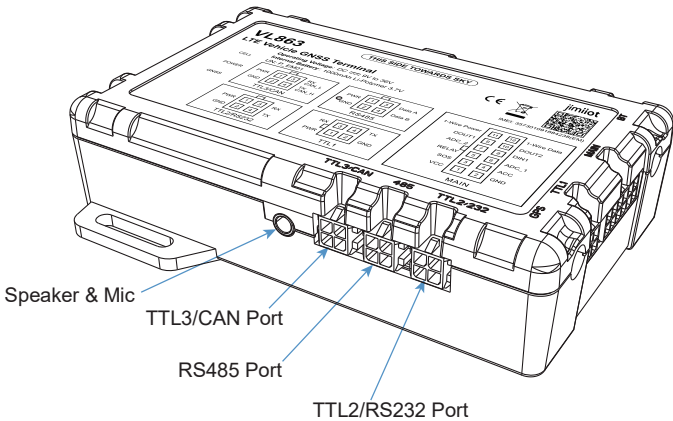
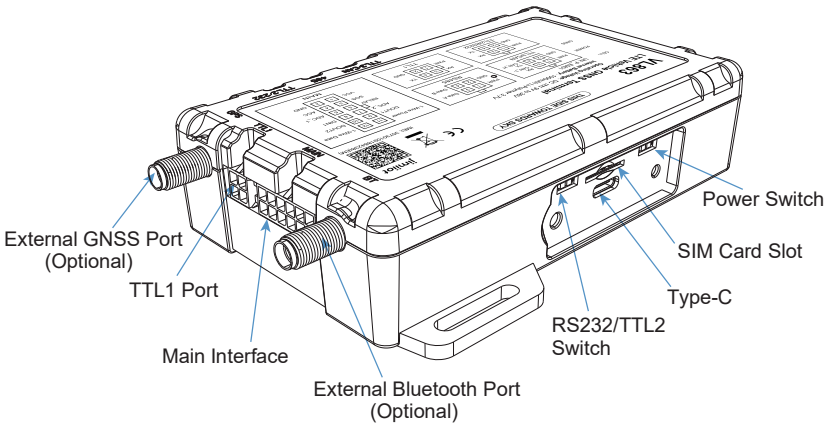

Interface Definitions

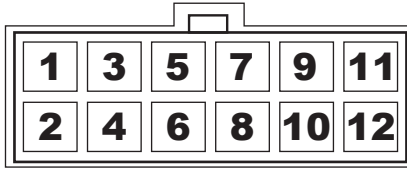

Pin	Pin Name	Color	Description
1	VCC	Red	Main power input (9-36V DC, with voltage detection)
2	GND	Black	Ground
3	SOS	Brown	I/O 1, fixed as SOS button input
4	ACC	Orange	High-level input, fixed as ignition (ACC) detection
5	Relay	Yellow	Digital output (open-drain) for external relay control
6	ADC_1	Purple	Analog input 1 (0-5V detection range, 0.1V resolution)
7	ADC_2	Purple	Analog input 2 (0-36V detection range, 0.3V resolution)
8	DIN 1	Brown	Configurable digital input (e.g., door status detection)
9	DOUT 1	Brown	Configurable digital output 1 (e.g., door lock control). Max load: 500mA.
10	DOUT 2	Brown	Configurable digital output 2 (e.g., door lock control). Max load: 500mA.
11	1-Wire Power	Blue	5V power output for 1-Wire peripherals.
12	1-Wire Data	Green	Data line for 1-Wire communication

Other interfaces

Num	Port	Function description
1	External GNSS Port	Optional. The internal antenna is used by default. An external antenna is recommended if the GNSS signal may be weak or obstructed.
2	External BT Port	Optional. The internal antenna is used by default. An external antenna can improve Bluetooth signal strength.
3	RS232/TTL2 Switch	Switch the port between RS232 and TTL2 functionality. Default: RS232.
4	Type-C	For firmware updates and debugging.
5	Power Switch	Turn the device ON or OFF.
6	Speaker & Mic	For remote listen-in or two-way audio communication.

LED Indication

Red (Power)

On for 0.3s and off for 0.3s	Low internal battery
On for 1s and off for 3s	Fully charged
On for 0.1s and off for 3s	Work correctly
Solid on	Charging (whose priority is higher than that of the low internal battery item)
Off	Internal battery insufficient/internal failure

Blue (GNSS)

On for 0.3s and off for 0.3s	In search of GNSS signals
Solid on	Position fixed.
Off	The GNSS module is in sleep or not working.

Green (Cellular)

On for 0.3s and off for 0.3s	Network initialization
On for 1s and off for 3s	Receive network signals normally
On for 0.1s and off for 3s	Device online
Off	No cellular signals are received or no SIM card is attached.

External Battery Status

The red, green, and blue indicators are on for 3 seconds.	Connect or disconnect the external battery.
---	---

Note:

To conserve power and operate discreetly, all three indicators will turn off after a few minutes of normal operation. They can be temporarily reactivated by cycling the external power supply or by sending a remote command.

Introduction

Specifications

Communication network 4G Cat.1 & 2G

VL863_LA
LTE-FDD: B1/B2/B3/B4/B5/B7/B8/B28
GSM: B2/B3/B5/B8

Frequency bands
VL863_EM
LTE-FDD: B1/B3/B7/B8/B20/B28
LTE-TDD: B34/B38/B39/B40/B41
GSM: B2/B3/B5/B8

GNSS GPS + BDS+ GLONASS

Positioning accuracy < 2.5m CEP

TTFF (open sky)
Avg. hot start: ≤2s
Avg. cold start: ≤38s

LED indication GNSS (Blue), Cellular (Green), Power (Red)

Battery 1000mAh/3.7V industry-grade Li-polymer battery
(2000mAh Optional)

Operating voltage 9–36VDC

Operating temperature –20°C to +70°C

Product weight 172g

Dimensions 115x69x28mm

Installation

Terminal Check

Visually check if the terminal is in good condition and if all accessories are included.

SIM Card Attachment

Prepare a standard SIM card. For the card size, see the following figure:

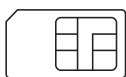

Standard ×



Micro ✓



Nano ×

Attach the SIM card, as shown in the following figure:

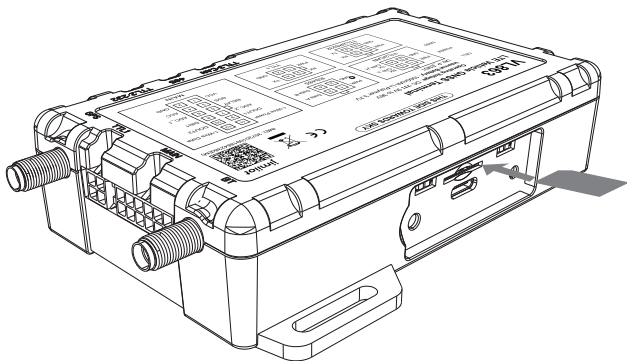

Note:

Before inserting or removing the SIM card, make sure that the device is completely powered off (external power supply disconnected and power switch set to OFF).

Wiring Diagram

Main Interface

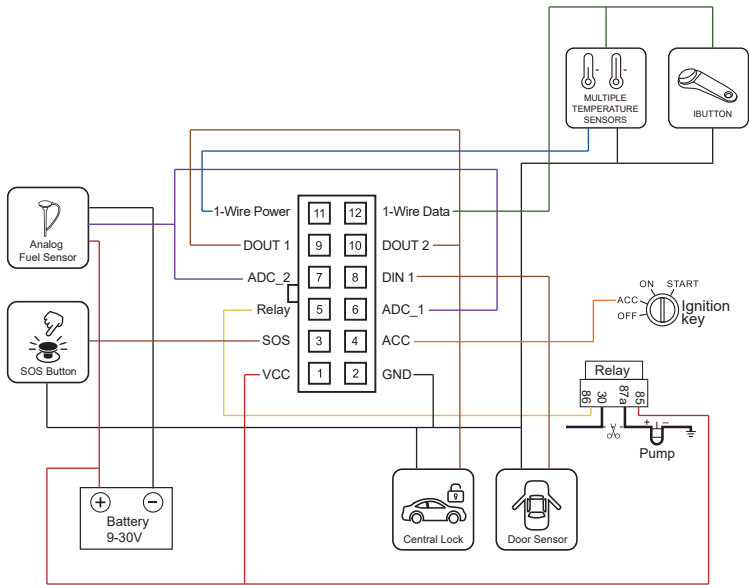

Power connection

The standard operating voltage is 9V to 36VDC. During installation, connect the red wire (VCC) to the vehicle's permanent power source (e.g., battery positive terminal) and the black wire (GND) to the vehicle's chassis ground.

Ignition detection

Connect the orange wire (ACC) to the vehicle's ACC line. This should be a true ignition wire that provides power only when the key is in the ON or START position.

Fuel pump control

Locate the vehicle's fuel pump power line and wire it according to the wiring diagram.

Currently, the magnetic strip card reader is only compatible with the VL863_EM model.

Installation Recommendation

Under the front windshield

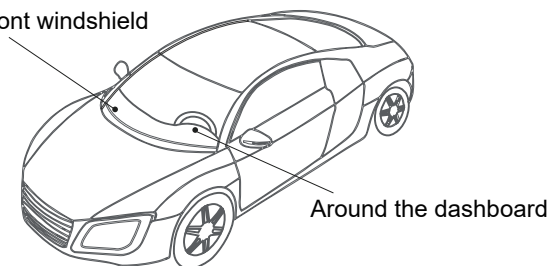

Around the dashboard

Note:

1. The device should face up to sky.
2. Metal thermal barrier or heating layers in some windshields may interfere with the GNSS signal.

Platform Operations

Logging In to the Platform

You can configure and control the terminal via the platform designated by your dealer.

You can download the mobile app via the URL provided by your dealer.



iOS



Android

Battery Safety

Please use batteries that are specified by the manufacturer of the terminal. The use of any non-original accessories will void the warranty services. The manufacturer will assume no repair liabilities for damages resulting from the use of non-original accessories.

- Avoid metal objects as they may cause short circuits on battery contacts.
- Do not bend or forcibly open the battery.
- Do not soak the battery in water or expose it to fire.
- It is forbidden to use batteries that are deformed, discolored, spilled, or package-damaged.
- It is forbidden to disassemble or modify the battery.

- Replacement of a battery with an incorrect type that can defeat a safe guard (for example, in the case of some lithium battery types).
- Disposal of a battery into fire or a hot oven, or mechanically crushing or cutting of a battery, that can result in an explosion.
- Leaving a battery in an extremely high temperature surrounding environment that can result in an explosion or the leakage of flammable liquid or gas.
- A battery subjected to extremely low air pressure that may result in an explosion or the leakage of flammable liquid or gas.

Troubleshooting

Type	Method
Unable to connect to tracking platform	<p>Check the APN and IP settings</p> <p>Check whether the data service of SIM card is enabled.</p> <p>Check the balance of SIM card.</p>
Tracker shows offline	<p>Check whether external power is still connected.</p> <p>Check if the vehicle entered network blind area.</p> <p>Check the balance of SIM card.</p>
Unable to locate	<p>Make sure the top side facing upward without metallic things shielded.</p> <p>Make sure it's not in area with no satellite coverage.</p>
Location drift	<p>In area with poor GNSS signal (tall building around or basement), drifting may happen.</p> <p>Check whether vibration happens around to trigger the accelerator.</p>
No command reply	<p>Make sure command format is correct.</p> <p>Vehicle may be in network blind area.</p> <p>Make sure SIM card is well inserted and has SMS service.</p>

Warranty instructions

1. The warranty is valid only when the warranty card is properly completed, and upon presentation of the proof of purchase consisting of the original invoice indicating the date of purchase, model and serial No. of the product. We reserve the right to refuse warranty if this information has been removed or changed after the original purchase of the product from the dealer.
2. Our obligations are limited to repair of the defect or replacement the defective part or at its discretion replacement of the product itself.
3. Warranty repairs must be carried out by our Authorized Service Centre. The warranty will be void, even if a repair has been attempted by any unauthorized service center.
4. Repair or replacement under the terms of this warranty does not provide right to extension or renewal of the warranty period.
5. The warranty is not applicable to cases other than defects in material, design or workmanship.

Maintenance Record

Date		Serviced by	
Product Model			
IMEI Number			
Failure Description			
Comments			